

Blackpool 6th beefs up its backup

Blackpool 6th Form College has around 1,600 full time advanced level students, using approximately 700 computers, almost exclusively Apple Macs running Mac OS X. It is one of the largest educational networks running Mac OS X in the UK. Peter Shuttleworth, one of the college's IT support engineers recently overhauled its data backup system using Archiware PresSTORE.

The previous system was based on EMC Retrospect, but support issues meant that a new solution was needed. Backups were failing, and full backups could only be achieved over a weekend. Also the addition of a few PCs to the network meant a cross-platform solution was needed. The data that was secured was then difficult to access. Often documents could be recreated faster than they could be retrieved from a backup, an unacceptable situation.

Of the cross platform solutions considered for the task, Archiware PresSTORE was chosen both on price and usability. Peter Shuttleworth commented "PresSTORE was bought to our attention by a 5 Mouse review in MacUser and while other options seemed convoluted, PresSTORE seemed very natural to use." Initially a trial version of PresSTORE was used, so that the product could be evaluated



properly. It was installed on an Apple Xserve without help and was configured to back up 30 Mac and PC servers. When the decision to go ahead was made, Blackpool 6th also invested in a Quantum Superloader 3, an LTO3 device sporting 16 slots with a barcode reader.

The results are impressive, with incredibly speedy backups, simple data retrieval and synthetic full backups that negate the need to interrupt server activities. A full backup of about 900GB that once required a weekend, now can be completed in 4 to 5 hours.

The barcode reader is fully supported by PresSTORE which enables fast location of tapes. Each magazine holds 8 cartridges, and the previous system would need to load each tape to see what is on it. PresSTORE uses the barcode reader to know which tapes are loaded. This makes data retrieval a quick and straightforward job, rather than something that would take hours.

Peter Shuttleworth gave a real life example. "This afternoon we had three students that had lost files, one just a single Word document, one had lost some large files and another had deleted all their work. In all there was 6 gigabytes of data that needed to be retrieved, but with the new system it was done in an hour. The old system would have taken overnight, and may not even have been worth doing for a single document."

Key Facts:

Customer Name:
The Blackpool Sixth Form College

Location: **Blackpool UK**

Nature of organisation:
Education/Training

Key products
PresSTORE
- Backup

Reseller:
GBM Digital Technologies



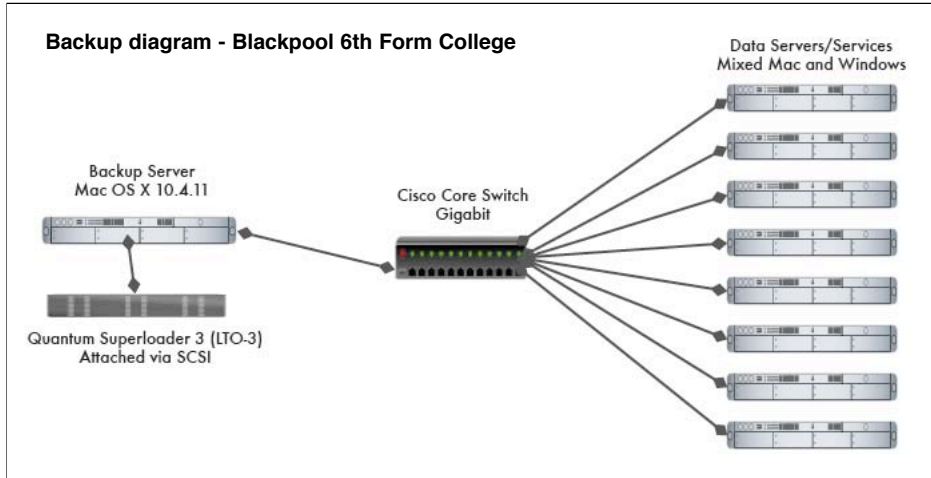
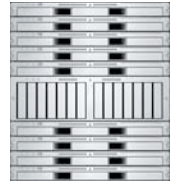

"We are able to offer a dramatically better service to our users, with less headaches from the support side."

*Peter Shuttleworth
Blackpool Sixth Form College*

Incremental backups are done each day and at the end of the week a full backup is performed. However, instead of tying up 30 machines to do the full backup, a synthetic backup is done, which doesn't use the network at all. A synthetic backup is simply a full backup compiled from the incremental backup tapes, so no pressure is put on the network, and no downtime is needed.

The system as a whole has very real and tangible benefits for both students and staff. More data is secured more regularly than the previous setup was capable of. But most importantly, the secured data is very accessible, which means time sensitive data is kept safe. So if somebody has spent a day working on a document, it doesn't take a week to save it.

Peter Shuttleworth said, "PresSTORE has lived up to all our expectations by providing a cost effective, fast, efficient and reliable solution to our needs. Because of PresSTORE we are able to

*From Left to right:
Lee Hopwood - IT Manager,
Peter Shuttleworth - IT Support Engineer*

offer a dramatically better service to our users, with less headaches from the support side."

"There are limited choices for systems that are capable of securing data from both Mac and PC platforms. PresSTORE proved to be the most capable method we could find."



JPY plc is the UK distributor for:



JPY plc
5 Surbiton Hill Road
Surbiton
Surrey
England KT6 4TW

Tel: 020-8390-8487
Email: sales@jpy.com
Web: www.jpy.com

